

Low-pulsation total evaporator up to 2.25 kW

The ChemTherm total vaporizer provides pulsation-free vapor dosing with fast response to load changes. Evaporation in the patented low volume evaporation tubes prevents the formation of large gas bubbles and ensures controlled and uniform evaporation. The evaporator can be conveniently disassembled by the customer for complete cleaning.

Technical specifications

Technical data:

- Operating range: 0 - 3000 g/h (water)
- Liquid media: various low-viscosity liquids that evaporate without residue, e.g. H₂O, methanol/ethanol, NH₃, isooctane, SiCl₄, alkanes, ...
- Temperature: max. 400 °C
- Material (parts in contact with media): 1.4571
- Process connections: G 1/8" with fitting on request, e.g. fitting (Swagelok) 6 mm
- Maximum pressure: 100 bar, incl. pressure test
- Seals: depending on medium: FKM, FFKM, metallic
- Installation position arbitrary
- Compact design, can be completely disassembled for cleaning
- Dimensions: approx. 130 mm x Ø 54 mm
- M5 thread for mounting

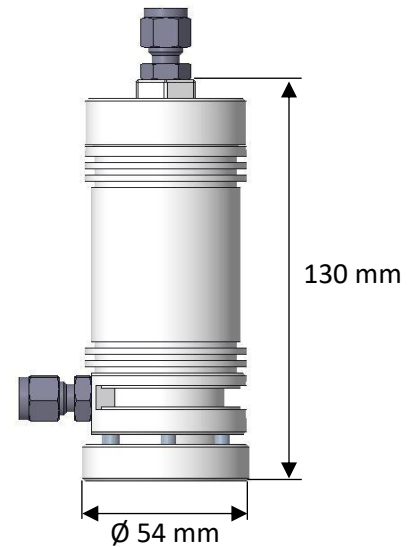

Electrical properties

- Power supply 220-240 VAC
- Power consumption 250 W, 750 W, 1250 W, 1750 W, 2250 W (depending on operating range)

Scope of delivery:

- Connection cable for heater and temperature sensor
- Marking in accordance with Pressure Equipment Directive Annex 1 Paragraph 3.3
- Manufacturer's certificate and documentation
- The evaporator is checked for functionality and fault tolerances before delivery
- Additional equipment, e.g., control units, dosing units, and other items can be provided upon request.

Contact us:



TGU ChemTherm TTI GmbH
info@chem-therm.de
Böblinger Straße 78
70199 Stuttgart