

Total Evaporator TV.1 (250 W to 2.25 kW)

The ChemTherm Total Evaporator provides pulsation-free vapor dosing with fast response to load changes. Evaporation in the patented low volume evaporation tubes prevents the formation of large gas bubbles and ensures controlled and uniform evaporation. The evaporator can be conveniently disassembled by the customer for complete cleaning.

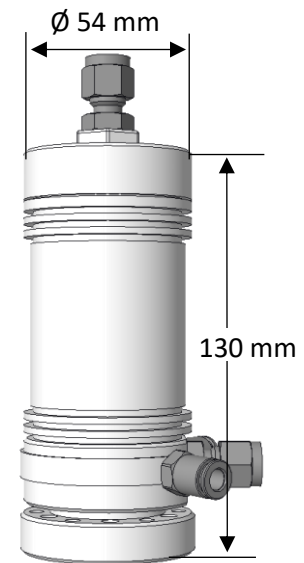

Technical specifications

Technical data:

- Operating range: 0 - 3000 g/h (water)
- Liquid media: H₂O, methanol, ethanol, NH₃, isooctane, SiCl₄, ...
- Temperature: max. 400 °C
- Material (parts in contact with media): 1.4571 (coating available)
- Process connections: G 1/8" with fitting on request, e.g. fitting (Swagelok) 6 mm
- Maximum pressure: 50 bar or 100 bar (High-pressure version), incl. pressure test
- Seals: FKM, FFKM, metallic
- Installation position arbitrary
- Compact design, can be completely disassembled for cleaning
- Dimensions: approx. 130 mm x Ø 54 mm
- M5 thread for mounting

Electrical properties

- Power supply: 230 VAC
- Power consumption: 250 W, 750 W, 1250 W, 1750 W, 2250 W

Scope of delivery:

- Connection cable for heater and temperature sensor
- Marking in accordance with Pressure Equipment Directive
- Manufacturer's certificate and documentation
- The evaporator is checked for functionality and faults before delivery
- Additional equipment, e.g., control units, dosing units, and other items can be provided upon request.

Contact us:



TGU ChemTherm TTI GmbH
info@chem-therm.de
Böblinger Straße 78
70199 Stuttgart